

Rittal – The System.

Faster – better – worldwide.



Schaltschrank-Kühlgerät
Cooling unit
Climatiseur
Koelaggregaat
Kylaggregat
Condizionatore per armadi
Refrigerador para armarios
エンクロージャー用
クーリングユニット

SK 3307.xxx

SK 3310.xxx

Montage-, Installations- und Bedienungsanleitung
Assembly and operating instructions
Notice d'emploi, d'installation et de montage
Montage- en bedieningshandleiding
Montage- och hanteringsanvisning
Istruzioni di montaggio e funzionamento
Instrucciones de montaje y funcionamiento
取扱説明書

ENCLOSURES

POWER DISTRIBUTION

CLIMATE CONTROL

IT INFRASTRUCTURE

SOFTWARE & SERVICES



Contents

1	Notes on documentation	4	5	Commissioning	16
1.1	Associated documents	4	6	Operation	17
1.2	CE labelling	4	6.1	Control using the e-Comfort controller	17
1.3	Retention of documents	4	6.1.1	Properties	17
1.4	Symbols used	4	6.1.2	Eco-mode	17
2	Safety notes	4	6.1.3	Launching test mode	18
3	Device description	5	6.1.4	General programming information	18
3.1	Functional description	5	6.1.5	Editable parameters	19
3.1.1	How it works	5	6.1.6	Programming overview	20
3.1.2	Control	5	6.1.7	Defining system messages for evaluation	21
3.1.3	Bus mode	5	6.1.8	Setting the master-slave identifier	22
3.1.4	Safety equipment	6	6.1.9	Evaluating system messages	22
3.1.5	Condensation	6	6.1.10	Resetting the e-Comfort controller	24
3.1.6	Filter mats	6	7	Inspection and maintenance	24
3.1.7	Door limit switch	6	7.1	General	24
3.1.8	Additional interface X3	6	7.1.1	Compressed air cleaning	24
3.2	Proper usage	7	8	Storage and disposal	26
3.3	Scope of supply	7	9	Technical specifications	26
4	Assembly and connection	7	10	List of spare parts	27
4.1	Choosing the installation site	7			
4.2	Assembly instructions	7			
4.2.1	General	7			
4.2.2	Layout of the electronic components in the enclosure	8			
4.3	Fitting the climate control module in the section door	8			
4.3.1	Assembly sequence	8			
4.3.2	Fitting the section door	9			
4.3.3	Fitting the climate control module	9			
4.3.4	Fitting the condensate discharge, the display into the section door, and the earthing and display cable	10			
4.4	Notes on electrical installation	11			
4.4.1	Connection data	11			
4.4.2	Overvoltage protection and supply line load	11			
4.4.3	Three-phase devices	12			
4.4.4	Door limit switch	12			
4.4.5	Notes on the flicker standard	12			
4.4.6	Potential equalisation	12			
4.5	Carrying out the electrical installation	12			
4.5.1	Bus connection (only in conjunction with several units with an e-Comfort controller)	12			
4.5.2	Installing the power supply	14			
4.6	Finalising assembly	16			
4.6.1	Installing the filter media	16			
4.6.2	Setting the filter mat monitor	16			

1 Notes on documentation

1 Notes on documentation

These assembly instructions are aimed at tradespersons who are familiar with the assembly and installation of the cooling unit, and at trained specialists who are familiar with the operation of the cooling unit.

1.1 Associated documents

There are two sets of instructions for the unit types described here:

- Assembly and installation instructions enclosed with the unit in the form of a paper document.
- Assembly, installation and operating instructions enclosed with the unit in the form of a PDF file (Adobe Acrobat) on CD-ROM.

We cannot accept any liability for damage associated with failure to observe these instructions. The instructions for the accessories used should also be observed where applicable.

1.2 CE labelling

The declaration of conformity is supplied with the unit as a separate document.

1.3 Retention of documents

These instructions and all associated documents are part of the product. They must be given to the plant operator. The operator is responsible for storage of the documents so they are readily available when needed.

1.4 Symbols used

Please observe the following safety instructions and other notes in this guide:

Symbol for an instructed action:

- The bullet point indicates that you should perform an action.

Safety and other instructions:



Danger!
Immediate danger to life and limb!



Caution!
Potential threat to the product and its environment.



Note:
Useful information and special features.

2 Safety notes

Please observe the following general safety notes when assembling and operating the unit:

- Assembly, installation and servicing may only be performed by properly trained specialists.
- Screw the enclosure to the floor to prevent it from tipping over when the cooling unit is installed.
- Do not obstruct the air inlet and air outlet of the cooling unit inside and outside the enclosure (see also section 4.2.2).
- The heat loss of the components installed in the enclosure must not exceed the specific useful cooling output of the cooling unit.
- When transporting the enclosure with the cooling unit externally mounted, always use an additional shipping brace (e.g. wooden structure made from square timber) to support the cooling unit at the bottom.
- Use only original spare parts and accessories.
- Do not make any changes to the cooling unit other than those described in these instructions or associated instructions.
- Risk of burn injuries! For cooling units with automatic condensate evaporation, the surface of the thermal element will get very hot during operation, and will remain so for some time afterwards.
- The mains connector of the cooling unit must only be connected and disconnected with the system de-energised. Connect the pre-fuse specified on the rating plate.

3 Device description

Depending on the model chosen, your cooling unit may vary in appearance from the illustrations contained in these instructions. However, the functions are identical in principle.

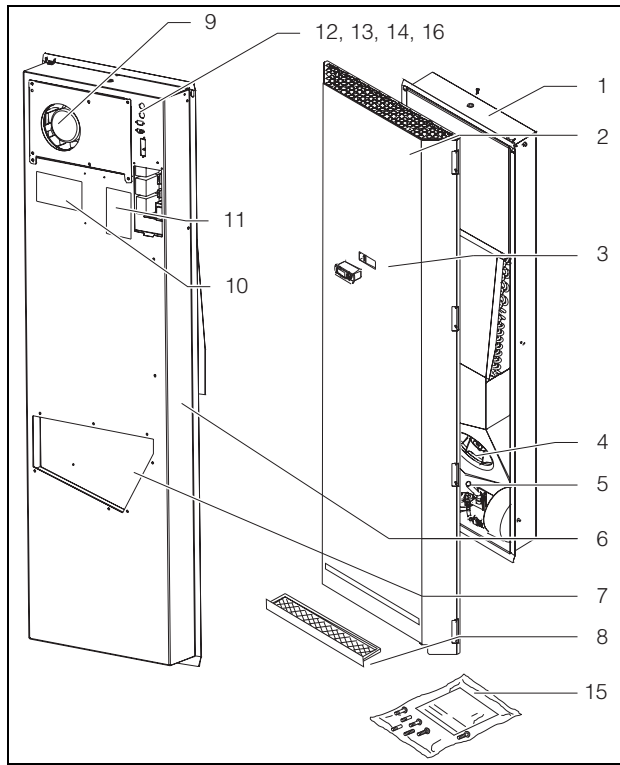

Fig. 1: Device description

Key

- 1 Climate control module
- 2 Section door
- 3 Display (controller)
- 4 Condenser fan
- 5 Condensate evaporator
- 6 Rear half of the enclosure
- 7 Air outlet hole
- 8 Filter (accessory)
- 9 Evaporator fan
- 10 Electrical wiring plan
- 11 Rating plate
- 12 X2 master-slave connection
- 13 X3 optional serial interface
- 14 X1 terminal strip
- 15 Dispatch bag
- 16 Miniature fuses, condensate evaporator

3.1 Functional description

The climate control door is designed to dissipate heat from enclosures and cool the air inside the enclosure in order to protect temperature-sensitive components. It is installed in place of the enclosure door.

3.1.1 How it works

The cooling unit (compression refrigeration system) is comprised of four main components (see Fig. 2): the evaporator (1), the refrigerant compressor (2), the condenser (3), and the control or expansion

valve (4), which are connected by suitable pipework. This circuit is filled with a readily boiling substance, the refrigerant. The R134a (CH_2FCF_3) refrigerant is free from chlorine. Its ozone destruction potential is 0, making it very eco-friendly. A filter dryer (5) which is integrated into the hermetically sealed cooling circuit provides effective protection against moisture, acid, dirt particles, and foreign bodies within the cooling circuit.

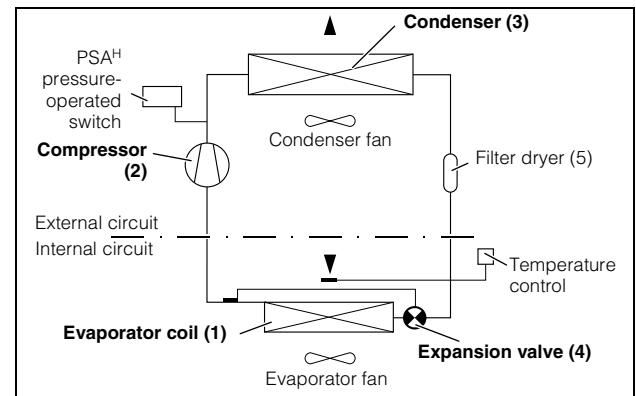

Fig. 2: Cooling circuit

In the evaporator coil (1), the liquid coolant is converted to a gaseous state. The energy needed for this purpose is taken from the enclosure air in the form of heat, which has the effect of cooling the enclosure air. In the compressor (2), the coolant is heavily compressed, so that it achieves a higher temperature inside the condenser (3) than the ambient air. This means that excess heat may be emitted to the ambient air via the surface of the condenser, as a result of which the temperature of the coolant drops and it is converted back into liquid. It is re-injected into the evaporator coil via a thermostatic expansion valve (4), which causes it to cool down further, and is then once again able to absorb the energy from the enclosure air in the evaporator coil. The whole cycle begins again.

3.1.2 Control

Rittal climate control doors are equipped with a e-Comfort controller, via which the functions of the cooling unit may be set (for display reading and extended functions, please refer to chapter "6 Operation", page 17).

3.1.3 Bus mode

The serial unit interface X2 allows you to create a bus connection with up to ten cooling units using the master-slave cable (shielded, three-wire cable, Model No. SK 3124.100).

This allows you to implement the following functions:

- Parallel unit control (the cooling units in the network can be switched on and off simultaneously)
- Parallel door status message ("door open")
- Parallel collective fault message

3 Device description

EN

Data is exchanged via the master-slave connection. During commissioning, assign an address to each unit that also includes the identifier “master” or “slave”.

3.1.4 Safety equipment

- In the cooling cycle, the cooling unit has a tested pressure-operated switch to EN 12 263 which is set to maximum PS (admissible pressure); this operates via an automatic reset device whenever the pressure drops again.
- Temperature monitoring prevents the evaporator coil from icing over. If there is a risk of icing, the compressor switches itself off and automatically switches itself back on again at higher temperatures.
- The refrigerant compressor and the fans are equipped with thermal winding shields to protect against excess current and excess temperatures.
- In order to allow a reduction of pressure inside the compressor and hence a safe restart, once it has been switched off (e.g. upon reaching the set temperature via the door limit switch function or via de-energising), the device will switch back on with a delay of 180 seconds.
- The device has two integral floating contacts on the connection clamp (system message relay with normally open contacts, terminal 3 – 5) which may be used to retrieve messages from the cooling unit, e.g. via PLC.

3.1.5 Condensation

At high levels of humidity and low temperatures inside the enclosure, condensation may form on the evaporator coil.

The climate control doors have an automatic electrical condensate evaporator. The thermal component used for this purpose is based on self-regulating PTC technology. Condensate arising on the evaporator coil is collected in a tank in the internal circuit of the cooling unit. When the water level rises, the water enters the PTC thermal component and is evaporated (through-flow heater principle). The water vapour streams out of the cooling unit with the airflow from the external fan.

The PTC thermal component is permanently connected and has no switchpoint. It is protected against short-circuits with miniature fuses (4AT). If the fuse has tripped, any condensation is drained off via the safety overflow.

To this end, a hose must be connected to the condensate nozzle (see “4.3.4 Fitting the condensate discharge, the display into the section door, and the earthing and display cable”, page 10).

3.1.6 Filter mats

The entire cooling unit condenser is covered with a dirt-repelling, easy-to-clean RiNano coating. In many cases, therefore, the use of filter media is unnecessary, particularly in the case of dry dusts.

For coarse dust and lint in the ambient air, we recommend installing an additional metal filter (available as an accessory) in the cooling unit. These may be cleaned with suitable detergents and reused.

Function of the filter mat monitor:

Dirt on the filter mat is automatically determined by measuring the temperature difference in the external circuit of the cooling unit. As the level of filter mat soiling rises, the temperature difference will increase. The nominal value of the temperature difference in the external circuit adapts automatically to the relevant operating points in the performance diagrams. Hence there is no need to readjust the nominal value for different operating points of the cooling unit.

3.1.7 Door limit switch

The climate control door may be operated with a door limit switch connected. The door limit switch is not included with the supply (available as an accessory, model no. PS 4127.010).

The door limit switch function causes the fans and the compressor in the cooling unit to be switched off after approximately 15 seconds when the enclosure door is opened (contacts 1 and 2 closed). This prevents the formation of condensation inside the enclosure while the enclosure door is open. In order to prevent damage to the unit, it is equipped with an ON delay: The evaporator fan cuts back in with a delay of approximately 15 seconds after the door has been closed, while the condenser fan and compressor switch on after approximately 3 minutes.

3.1.8 Additional interface X3



Note:

The electrical signals at the interface are of an extra-low voltage (not extra-low safety voltages to EN 60 335).

An additional interface card may be connected to the 9-pole SUB-D connector X3 in order to incorporate the cooling unit into superordinate monitoring systems (available as an accessory, interface card Model No. SK 3124.200).

3.2 Proper usage

Rittal climate control doors were developed and designed in accordance with the state of the art and the recognised rules governing technical safety. Nevertheless, if used improperly, they may pose a threat to life and limb or cause damage to property. The climate control door is only intended for cooling enclosures. Any other use is deemed improper. The manufacturer will not be liable for any damages caused as a result of improper use, or for incorrect assembly, installation or use. All risk is borne solely by the user.

Proper usage also includes the observation of all valid documents and compliance with the inspection and servicing conditions.

3.3 Scope of supply

The unit is supplied in a packaging unit in a fully assembled state.

Please check the delivery for completeness:

Qty.	Description
1	Climate control module
1	Dispatch bag:
1	– Assembly and installation instructions
1	– Assembly, installation and operating instructions on CD-ROM
1	– Safety notes
1	– Declaration of conformity
1	– Connector X1
1	– Ring screw
2	– Screws, contact washers
1	Cable tie for strain relief

Tab. 1: Scope of supply

4 Assembly and connection

4.1 Choosing the installation site

When choosing the installation site for the enclosure, please observe the following:

- The site for the enclosure, and hence the arrangement of the cooling unit, must be carefully selected so as to ensure good ventilation. Depending on the siting of the unit, if several units are installed directly adjacent to one another, the distance from the wall must be at least 200 mm.
- The climate control door must be installed and operated in a vertical position (maximum deviation: 2°).
- The site must be free from excessive dirt and moisture.
- The ambient temperature must not exceed 55°C.
- It must be possible to fit a condensate discharge (see “4.3.4 Fitting the condensate discharge, the display into the section door, and the earthing and display cable”, page 10).
- The mains connection data as stated on the rating plate of the unit must be guaranteed.

4.2 Assembly instructions

4.2.1 General

- Check that the packaging does not show any signs of damage. Traces of oil on damaged packaging are an indication of refrigerant loss and leakages. Packaging damage may be the cause of a subsequent functional failure.
- The enclosure must be sealed on all sides (IP 54). Increased condensation will occur if the enclosure is not airtight.
- In order to avoid excessive condensation inside the enclosure, we recommend installing a door limit switch (e.g. PS 4127.010) which deactivates the cooling unit when the enclosure door is opened (see “3.1.7 Door limit switch”, page 6).

4 Assembly and connection

4.2.2 Layout of the electronic components in the enclosure



Caution!

Risk of condensation!

When arranging the components inside the enclosure, please ensure that the cold airflow from the cooling unit is not directed at active components. Please also ensure that the cold airflow is not directed at the warm exhaust airflow from active components such as converters. This may lead to an air short-circuit and therefore prevent adequate climate control, or may even cause the cooling unit's internal safety devices to cease cooling operation.

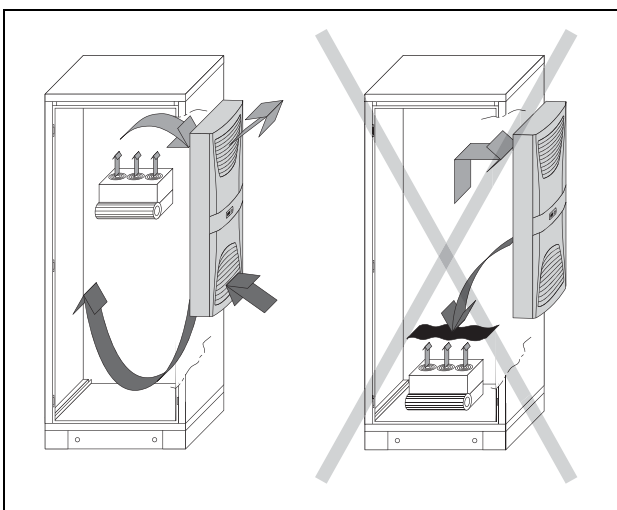

Fig. 3: Never direct the cold airflow at active components



Note:

In order to ensure perfect operation of the climate control door, an enclosure base/plinth at least 100 mm high is required.

It is important to ensure even air circulation inside the enclosure. Under no circumstances should air inlet and outlet openings be obstructed, otherwise the cooling performance of the unit will be reduced. Ensure the distance "x" (see Fig. 4) from electronic components and other installed enclosures so that the required air circulation is not obstructed and prevented.

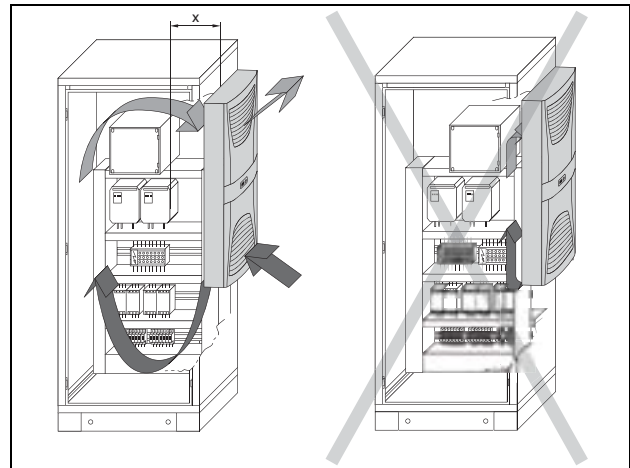

Fig. 4: Air circulation inside the enclosure

4.3 Fitting the climate control module in the section door

4.3.1 Assembly sequence

The climate control module must be fitted in the following sequence:

1. Fit the section door (see "4.3.2 Fitting the section door", page 9)
2. Fit the climate control module (see "4.3.3 Fitting the climate control module", page 9)
3. Fit the condensate discharge, the display into the section door, and the earthing and display cable (see "4.3.4 Fitting the condensate discharge, the display into the section door, and the earthing and display cable", page 10)

4 Assembly and connection

EN

4.3.2 Fitting the section door

Screw-fasten the section door to the TS enclosure using the four preassembled hinges.



Fig. 5: Section door with hinges



Note:

Take care to ensure that the hinges labelled "S" are mounted on the top and bottom of the section door.



Fig. 6: Hinge labelled "S"

4.3.3 Fitting the climate control module



Note:

The climate control door must always be fitted by two people.

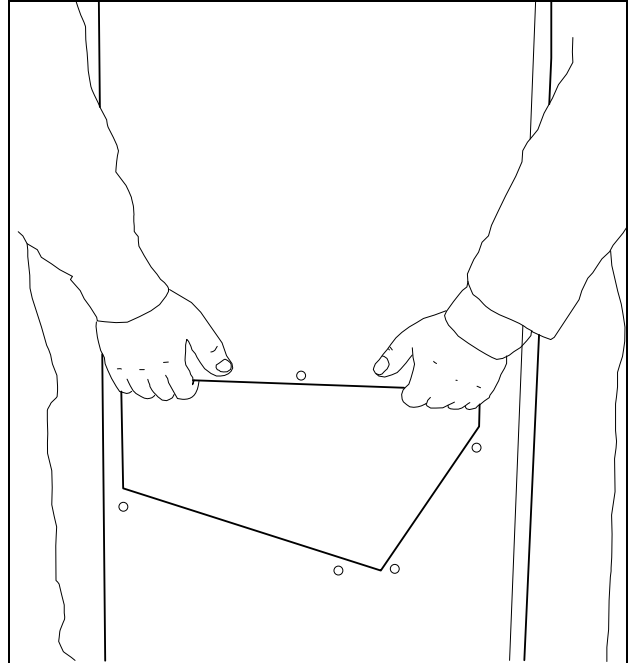

Fig. 7: Transporting the climate control door

- Insert the climate control module into the lower rail on the inside of the fitted section door.



Fig. 8: Fit the climate control module in the section door

- Screw-fasten the module to the top edge of the section door using two screws.

4 Assembly and connection

4.3.4 Fitting the condensate discharge, the display into the section door, and the earthing and display cable

Fitting the condensate discharge:

The condensate discharge hose is pre-connected to the overflow nozzle of the collecting tank in the factory. The hose should be routed out of the section door via the air duct channel on the bottom right of the unit.

The condensate discharge

- must be laid with a suitable and constant gradient (no siphoning)
- must be laid without kinks
- must not have a reduced cross-section if extended.



Fig. 9: Route the condensate discharge out of the unit

Fitting the display into the section door:

- Insert the display into the section door opening from the outside.

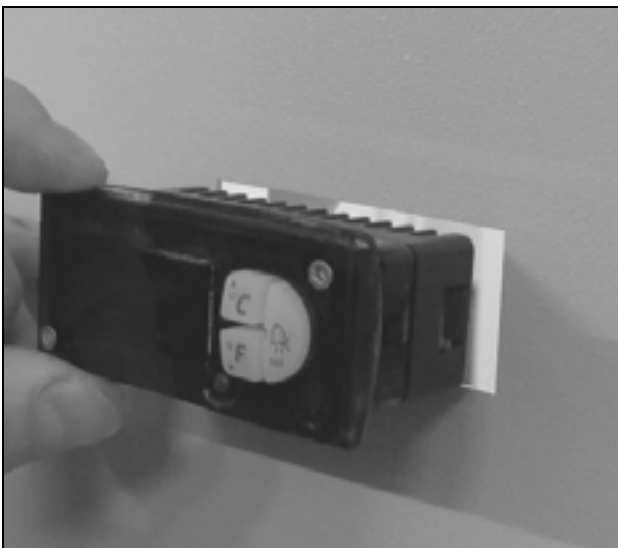

Fig. 10: Insert the display into the section door opening

- Secure the display to the section door using the two screws on the section door and attach the trim panel.

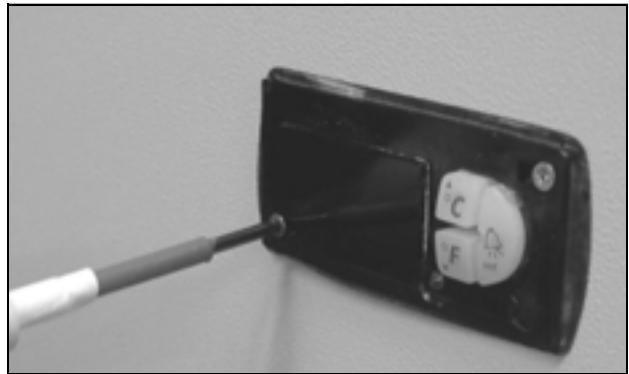

Fig. 11: Secure the display



Fig. 12: Attach the trim panel

Fit the earth onto the section door:

- Re-attach the earthing cable to the inside of the section door.

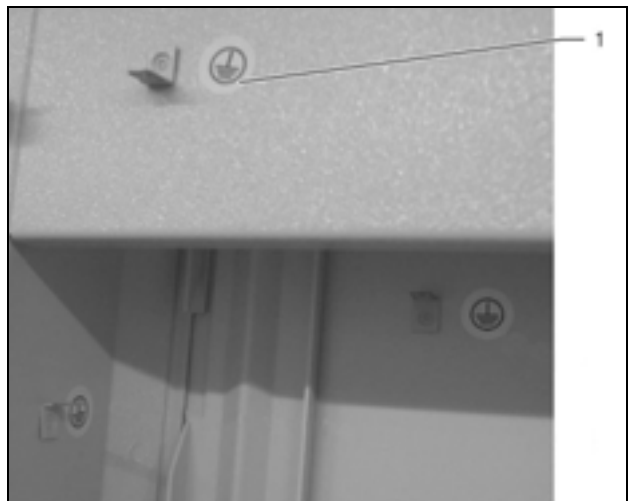

Fig. 13: Connections for the earthing cable

Key

- 1 Connect the earthing cable to the section door

Fit the display cable:

- Release the cover plate on the inside of the section door.



Fig. 14: Release the cover plate

- Connect the controller cable on the climate control module into the display.



Fig. 15: Connect the display connection cable

- Push the cover plate back over the display on the inside of the section door and clamp it securely.



Fig. 16: Insert the cable sleeve



Fig. 17: Slide on the cover

4.4 Notes on electrical installation

When carrying out the electrical installation, it is important to observe all valid national and regional regulations as well as the provisions of the responsible power supply company. Electrical installation must only be carried out by a qualified electrician who is responsible for ensuring compliance with the existing standards and regulations.

4.4.1 Connection data

- The connected voltage and frequency must correspond to the values stated on the rating plate.
- The cooling unit must be connected to the mains via an all-pin isolating device, which ensures at least 3 mm contact opening when switched off.
- No additional temperature control may be connected upstream of the unit at the supply end.
- Install the pre-fuse specified on the rating plate to protect the cable and equipment from short-circuits.
- The mains connection must ensure low-noise potential equalisation.

4.4.2 Overvoltage protection and supply line load

- The unit does not have its own overvoltage protection. Measures must be taken by the operator at the supply end to ensure effective lightning and overvoltage protection. The mains voltage must not exceed a tolerance of $\pm 10\%$.
- In accordance with IEC 61 000-3-11, the unit is intended solely for use at sites with a continuous current-carrying capacity (incoming mains power supply) of more than 100 A per phase and with a supply voltage of 400/230 V. If necessary, the power supply company must be consulted to ensure that the continuous current-carrying capacity at the point of connection to the public grid is sufficient for connection of such a unit.

4 Assembly and connection

EN

- The fans and compressors in single- and three-phase units are intrinsically safe (thermal winding protection). This also applies to transformer versions, types SK 3307.710, SK 3310.710, and to special-voltage units which are likewise equipped with a transformer.
- Install the slow pre-fuse specified on the rating plate (miniature circuit-breaker with appropriate characteristic – e. g. K characteristic – or fuse gG standard type, power circuit-breaker or transformer circuit-breaker) to protect the cable and equipment from short-circuits. Select a suitable power circuit-breaker/transformer circuit-breaker in accordance with the information specified on the rating plate: Set it to the minimum specified value. This will achieve the best short-circuit protection for cables and equipment.
Example: Specified setting range 6.3 – 10 A; set to 6.3 A.

4.4.3 Three-phase devices

- The three-phase version of types SK 3307.740, SK 3310.740 must be connected to a TN network using a power circuit-breaker with star earth point (setting range as per rating plate). Special-voltage three-phase units must be protected with a transformer circuit-breaker (category AC-3) as per the rating plate.
- Units designed for three phase 400/460 V feature additional monitoring of the rotary field or the absence of a phase. If the rotary field is incorrect or a phase is absent, the unit will not run.

4.4.4 Door limit switch

- Each door limit switch must only be assigned to one cooling unit.
- Several door limit switches may be connected in parallel and operated on one cooling unit.
- The minimum cross-section of the connection cable is 0.3 mm² for a cable length of 2 m. We recommend the use of a shielded cable.
- The line resistance to the door limit switch must not exceed a maximum of 50 Ω.
- The door limit switch only supports a floating connection; no external voltages.
- The contact of the door limit switch must be closed when the door is open.

The safety extra-low voltage for the door limit switch is provided by the internal power pack: Current approx. 30 mA DC.

- Connect the door limit switch to terminals 1 and 2 of the connector.

4.4.5 Notes on the flicker standard

The flicker limits specified in standard EN 61 000-3-3 or -3-11 are adhered to, provided the supply impedance is less than approx. 1.5 Ω.

Where necessary, the unit operator should measure the connected impedance or consult the responsible power supply company. If there is no way of influencing the supply impedance and sensitive installed components (e.g. BUS) are subjected to interference, a line reactor or starting-current limiting device should be connected upstream of the cooling unit to restrict the startup current of the cooling unit.

4.4.6 Potential equalisation

If, for EMC reasons, the unit is to be integrated into the existing potential equalisation system at the customer, a conductor with a larger nominal cross-section can be connected to the potential equalisation connection point (attachment points) on the climate control module.

According to the standard, the PE conductor in the mains connection cable is not classified as an equipotential bonding conductor.

4.5 Carrying out the electrical installation

The female connector contained in the dispatch bag should be fitted with a connection cable. The clip-in cable tie supplied loose should be used as strain relief for the connection cable (punching is adjacent to the clamping strip).



Fig. 18: Attach the clip-in cable tie for strain relief to the front half of the climate control module housing

4.5.1 Bus connection (only in conjunction with several units with an e-Comfort controller)

When using several cooling units, the serial device interface X2 can be used to connect up to ten cooling units with the bus cable (Model No. SK 3124.100).



Note:

The electrical signals at the X2 interface are of an extra-low voltage (not extra-low safety voltages to EN 60 335-1).

4 Assembly and connection

EN

When interconnecting, please note the following:

- De-energise the cooling units to be connected.
- Ensure proper electrical insulation.

- Make sure the cables are not laid in parallel to power lines.
- Make sure that the lines are short.

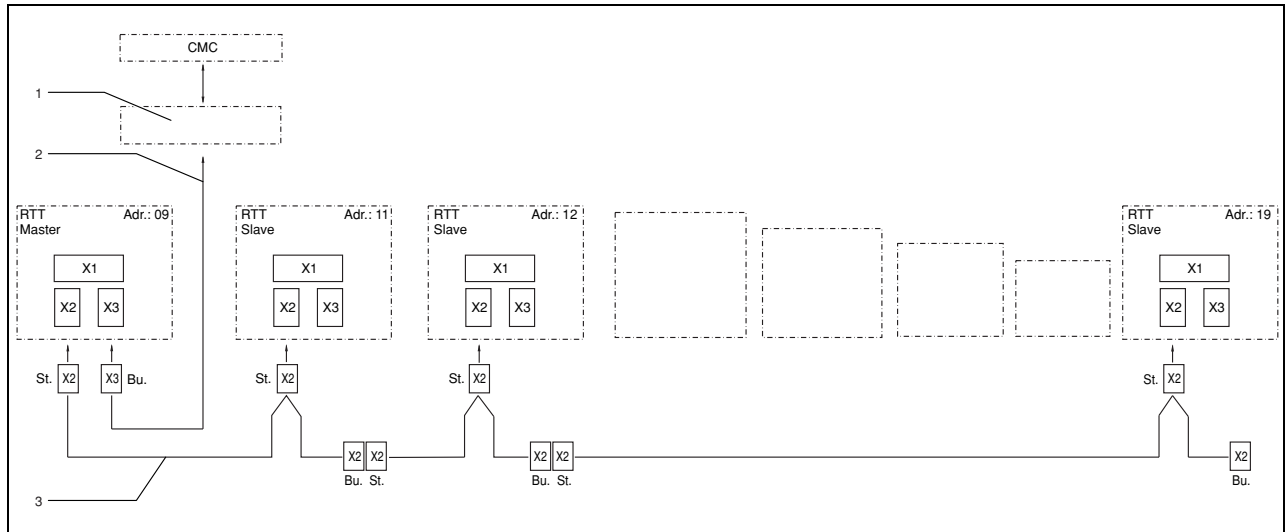

Fig. 19: Connection example: Master-slave operation

Key

- | | | | |
|-----|--|------|---------------------------------------|
| 1 | Serial interface card (Model No. SK 3124.200) | X2 | Master-slave connection Sub-D, 9-pole |
| 2 | Serial interface cable | X3 | Serial interface Sub-D, 9-pole |
| 3 | Master-slave bus cable (Model No. SK 3124.100) | St. | Sub-D connector, 9-pole |
| RTT | Rittal TopTherm cooling units | Bu. | Sub-D jack, 9-pole |
| X1 | Supply connection/door limit switch/alarms | Adr. | Address |

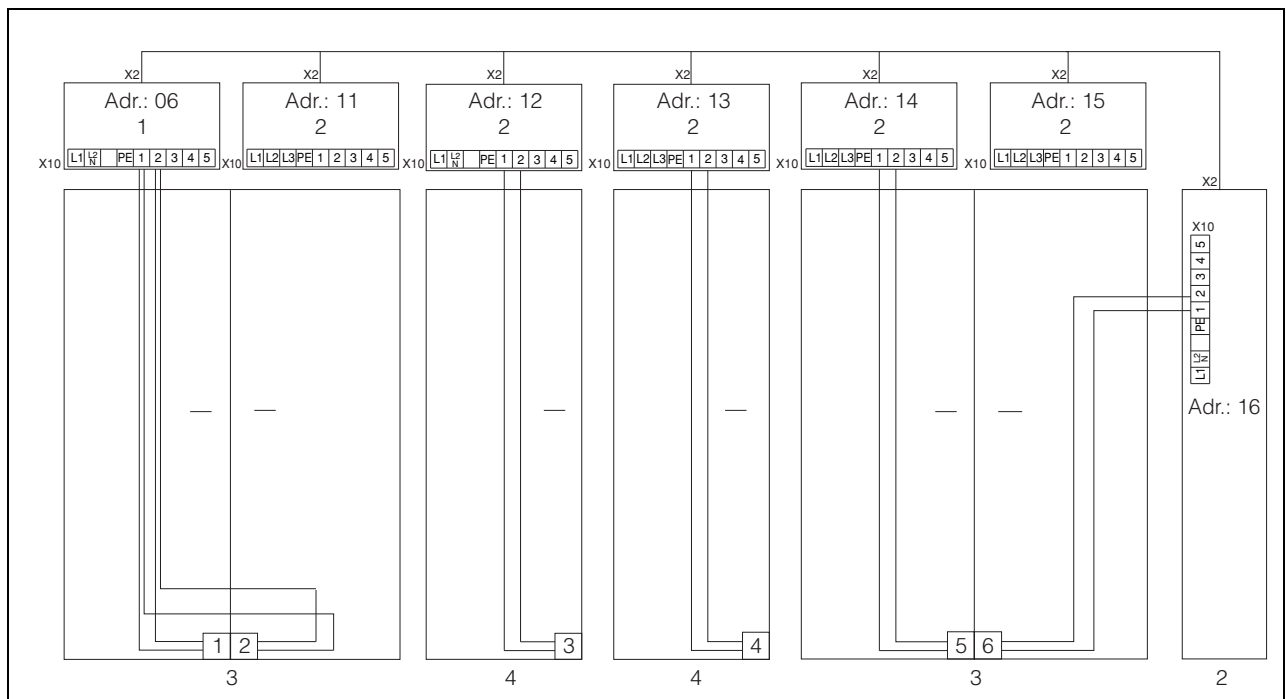

Fig. 20: Connection example: Door limit switch and master-slave operation

Key

- | | |
|---|---|
| 1 | Master cooling unit |
| 2 | Slave cooling units |
| 3 | 2-door enclosure with two door limit switches |
| 4 | Enclosure with door limit switch |

4 Assembly and connection

EN

4.5.2 Installing the power supply

- Complete the electrical installation by following the wiring plan on the rear of the cooling unit (see Fig. 1 on page 5, no. 10).

- If you would like the system messages from the cooling unit to be evaluated via the system message relays, you should also connect a suitable low-voltage cable to connection clamps 3 – 5.

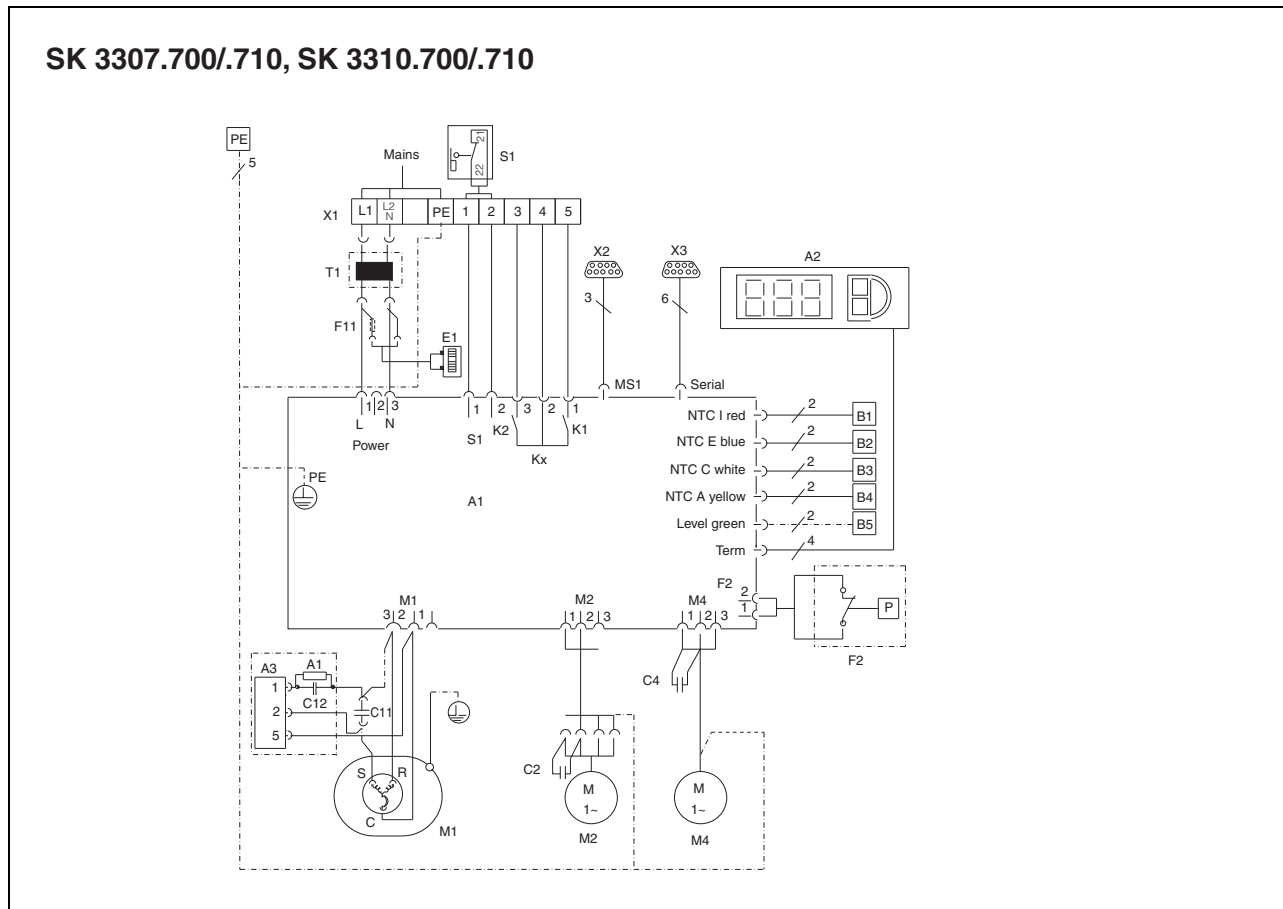

Fig. 21: Electrical wiring plan no. 1

SK 3307.740, SK 3310.740

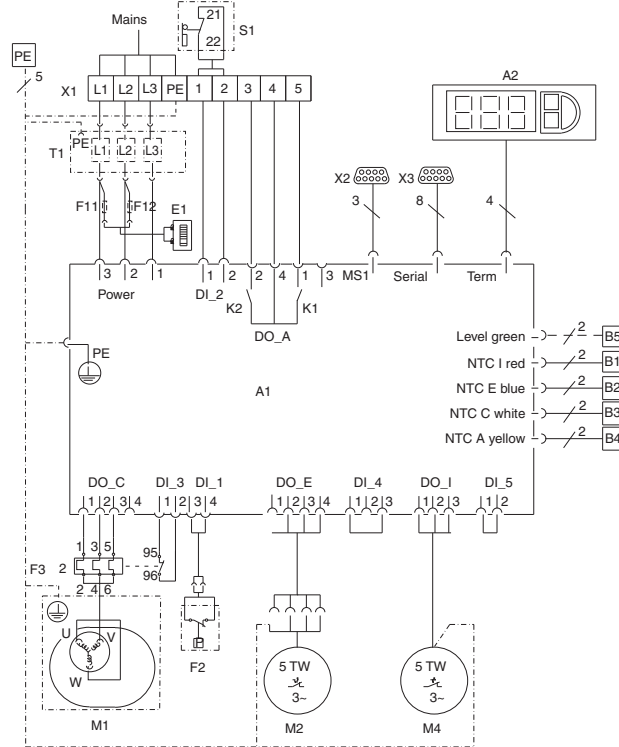

Fig. 22: Electrical wiring plan no. 2

Legend

- A1 Power PCB
- A2 e-Comfort controller
- A3 Starter relay and RC element
- B1 Temperature sensor, internal temperature
- B2 Icing hazard temperature sensor
- B3 Condenser temperature sensor
- B4 Ambient temperature sensor
- B5 Condensate warning sensor (optional)
- C1.2 Start-up capacitor
- C1.1, C2 – C4 Running capacitors
- E1 Condensate evaporator
- F2 PSA^H pressure-operated switch (33xx.1x0 has a jumper instead of a pressostat)
- F3 Contact overload protection
- F11/F12 Miniature fuses, condensate evaporator
- K1 Relay collective fault 1
- K2 Relay collective fault 2
- M1 Compressor
- M2 Condenser fan
- M4 Evaporator fan
- S1 Door limit switch (without door limit switch: terminal 1, 2 open)
- T1 Transformer (optional)
- X1 Main terminal strip
- X2 Master-slave connection
- X3 Optional interface



Note:

For technical data refer to the rating plate.

AC cos f = 1	DC L/R = 20 ms
I max. = 2 A U max. = 250 V	I min. = 100 mA U max. = 200 V U min. = 18 V I max. = 2 A

Tab. 2: Contact data

5 Commissioning

4.6 Finalising assembly

4.6.1 Installing the filter media

The entire cooling unit condenser is covered with a dirt-repelling, easy-to-clean RiNano coating. In many cases, therefore, the use of filter media is unnecessary, particularly in the case of dry dusts.

For dry, coarse dust and lint in the ambient air, we recommend installing a filter in the cooling unit. For air containing oil condensation, we recommend the use of metal filters (accessory SK 3284.210). When used in textile plants with heavy lint contamination, lint screens should be used (available as an optional extra).

- Slide the metal filter into the bottom of the section door.
- When removing from below, grasp through the hole and pull the filter out forwards.

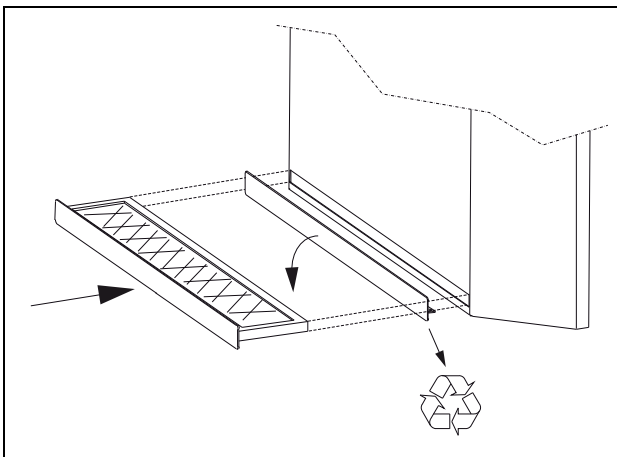

Fig. 23: Install the filter mat

4.6.2 Setting the filter mat monitor

Function of the filter mat monitor:

Dirt on the filter mat is automatically detected by measuring the temperature difference in the external circuit of the cooling unit (see “6.1.6 Programming overview”, page 20). As the level of filter mat soiling rises, the temperature difference will increase. The nominal value of the temperature difference in the external circuit adapts automatically to the relevant operating points in the performance diagrams. Hence there is no need to readjust the nominal value for different operating points of the cooling unit.

5 Commissioning



Caution! Risk of damage!

The oil must be collected in the compressor in order to ensure effective lubrication and cooling.

Do not operate the cooling unit for at least 30 minutes after assembling the equipment.

- Once all the assembly and installation work is complete, switch on the power supply to the cooling unit.

The cooling unit starts running:

- First the software version of the controller appears for approx. 2 sec., followed by “ECO” for activated eco-mode. Then the enclosure internal temperature appears on the 7-segment display.

You can now make your individual settings on the unit e.g. set the temperature or assign the network identifier etc. (refer to chapter “6 Operation”).

6 Operation

You can operate the cooling unit using the display (controller) on the front of the device (Fig. 1, no. 3, page 5).

6.1 Control using the e-Comfort controller

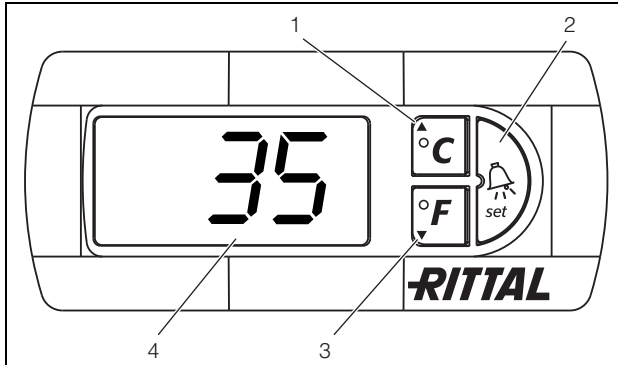

Fig. 24: e-Comfort controller

Key

- 1 Programming button, also display of the set temperature unit (degrees Celsius)
- 2 Set button
- 3 Programming button, also display of the set temperature unit (degrees Fahrenheit)
- 4 7-segment display

6.1.1 Properties

- Four voltage variants are supported:
 - 115 V, with transformer, single phase
 - 230 V
 - 400 V, 2-phase
 - 400/460 V, 3-phase
- Integral start-up delay and door limit switch function.
- Protective function to prevent icing.
- Monitoring of all motors (compressor, condenser fan, evaporator fan).
- Phase monitoring for three-phase units.
- Master-slave function with a maximum of ten units. One device functions as a master unit. Once the set temperature is reached by one of the connected slave devices or in the event of the door limit switch function, the affected slave unit will report to the master unit, which will switch all the other cooling units on or off as required.
- Switching hysteresis: Adjustable within the range 2 – 10 K, preset to 5 K.
- Visualisation of the current enclosure internal temperature and all error messages in the 7-segment display.
- Using an interface card (Model No. SK 3124.200), the unit may be incorporated into higher-level remote monitoring systems such as the Rittal Computer Multi Control CMC.

The cooling unit operates automatically i.e. after switching on the power supply, the evaporator fan (see Fig. 2, page 5) starts to run and circulates the internal enclosure air. The compressor and condenser fan are regulated by the e-Comfort controller. The e-Comfort controller has a 7-segment display (Fig. 24, no. 4). After switching on the power supply, the current software version initially appears on this display for approx. 2 seconds, as well as the activated eco-mode. Followed by a preset option (e. g. t10) or the temperature.

In regular operation, the display shows both the temperature (in degrees Celsius or Fahrenheit – users may switch between the two) and any error messages. The current enclosure internal temperature is usually displayed permanently. In the event of an error message, this will alternate with the temperature display. The unit is programmed using buttons 1 – 3 (Fig. 24). The relevant parameters also appear in the display.

6.1.2 Eco-mode

All Rittal TopTherm cooling units with e-Comfort controller from firmware 3.2 have the energy-saving eco-mode, which is activated in the delivered state.

The eco-mode is used to save energy in the cooling unit if there is no thermal load, or there is a low thermal load in the enclosure (e. g. standby operation, no production or weekend).

During this process the evaporator fan in the internal circuit is switched off as appropriate if the actual enclosure internal temperature drops to 10 K below the setpoint temperature set. To reliably measure the internal temperature also during this process, the fan starts cyclically for 30 sec. (see Fig. 25). If the internal temperature reaches the range 5 K below the setpoint set again, the fan switches back to continuous operation.

If required, the eco-mode can be deactivated via the control display. For this purpose switch the parameter from 1 to 0 in the programming level (see Tab. 3, page 19). The fan then runs continuously.

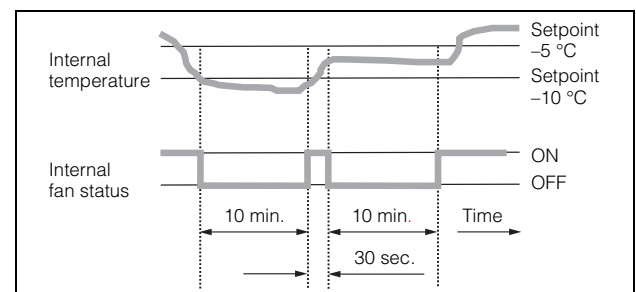

Fig. 25: Diagram of eco-mode

6 Operation

EN

6.1.3 Launching test mode

The e-Comfort controller is equipped with a test function whereby the cooling unit commences cooling operation independently of the set temperature or door limit switch function.

- Simultaneously press buttons 1 and 2 (Fig. 24) for at least five seconds.

The cooling unit will commence operation.

Test mode is completed after approximately 5 minutes. The unit switches off and changes to normal operation.

6.1.4 General programming information

Using buttons 1, 2 and 3 (Fig. 24) you can change 24 parameters within the preset ranges (min. value – max. value).

Tables 3 and 4 show the parameters which can be altered. Fig. 26 on page 20 shows which buttons must be pressed.



Note on switching hysteresis:

With a low hysteresis and short switching cycles, there is a risk that cooling may not be adequate or that only partial sections of the enclosure are cooled. If the cooling unit is oversized and compressor running times are < 1 minute the switching hysteresis is automatically increased to protect the cooling unit.

Note on temperature settings:

With the e-Comfort controller, the temperature is preset at the factory to +35°C. In order to save energy, do not set the temperature lower than that actually necessary.

Note on useful cooling output:

Interactive performance diagrams for calculating the useful cooling output may be found at www.rittal.com.

In principle, the programming is identical for all editable parameters.

To enter programming mode:

- Press button 2 (“Set”) for approx. five seconds.

The controller is now in programming mode. While in programming mode, if you do not press any buttons for approx. 30 seconds, the display will first flash, then the controller will switch back to normal display mode. The “Esc” display indicates that any changes made have not been saved.

- Press the programming buttons ▲ (°C) or ▼ (°F) to switch back and forth between the editable parameters (see tables 4 and 5).
- Press button 2 (“Set”) to select the displayed parameter for editing.

The current value of this parameter is displayed.

- Press one of the programming buttons ▲ (°C) or ▼ (°F).

The “Cod” display will appear. In order to be able to change a value, you must enter the authorisation code “22”.

- Keep the programming button ▲ (°C) held down until “22” appears.
- Press button 2 (“Set”) to confirm the code.

You can now alter the parameter within the preset limits.

- Press one of the programming buttons ▲ (°C) or ▼ (°F) until the required value appears.
- Press button 2 (“Set”) to confirm the change.

You can now alter other parameters in the same way. There is no need to re-enter the authorisation code “22”.

- To exit programming mode, press button 2 (“Set”) again for approximately five seconds.

“Acc” will appear in the display to indicate that the changes have been saved. The display will then switch back to regular operation (enclosure internal temperature).

You can also program the e-Comfort controller using a diagnosis software package (Model No. SK 3159.100), the supply of which also includes a connection cable to the PC. The cable connector on the rear of the e-Comfort controller display serves as an interface.

6.1.5 Editable parameters

See also Fig. 26 on page 20.

Progr. level	Display screen	Parameter	Min. value	Max. value	Factory setting	Description
1	St	Internal enclosure temperature setpoint T_i	20	55	35	The setting of the enclosure internal temperature is preset at the factory to 35°C and may be altered within a range of 20 – 55°C.
2	Fi	Filter mat monitoring	10	60	99 (= off)	To activate filter mat monitoring, set the display to at least 10 K above the temperature differential displayed in programming mode “Fi”. Filter mat monitoring is preset to “deactivated” in the factory (99 = off).
3	Ad	Master-slave identifier	0	19	0	See “6.1.8 Setting the master-slave identifier”, page 22.
4	CF	Temperature conversion °C/°F	0	1	0	The temperature display can be switched from °C (0) to °F (1). The corresponding LED displays the current unit of temperature.
5	H1	Setting for switching difference (hysteresis)	2	10	5	The cooling unit is preset in the factory to a switching hysteresis of 5 K. This parameter should only be changed in consultation with us. Please contact us for advice.
6	H2	Differential for error message A2	3	15	5	If the internal enclosure temperature exceeds the set value by more than 5 K, then error message A2 (enclosure internal temperature too high) appears on the display terminal. If necessary, the differential may be altered here within the range of 3 – 15 K.
26	ECO	Eco-mode operation	0	1	1	Eco-mode OFF: 0 / Eco-mode ON: 1

Tab. 3: Editable parameters

6 Operation

6.1.6 Programming overview

EN

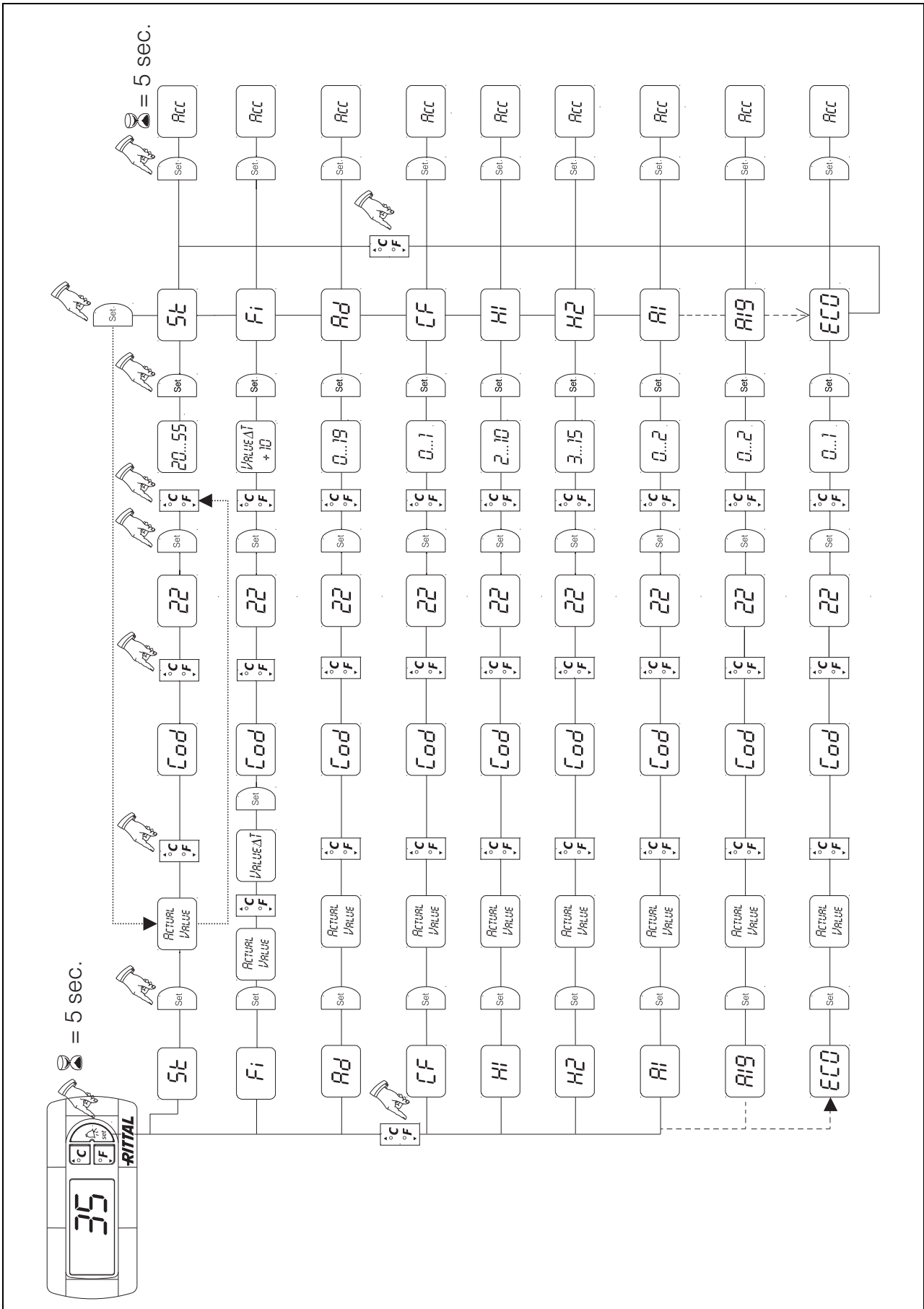

Fig. 26: Programming overview

6.1.7 Defining system messages for evaluation

System messages are shown on the display screen of the e-Comfort controller via the displays A1 to A20 and E0.

A more detailed explanation of the system messages may be found in section “6.1.9 Evaluating system messages”, page 22.

See also Fig. 26 on page 20.

Progr. level	Display screen	Min. value	Max. value	Factory setting	Type or location of fault
7	A1	0	2	0	Enclosure door open
8	A2	0	2	0	Internal temperature of enclosure too high
9	A3	0	2	0	Filter monitoring
10	A4	0	2	0	Ambient temperature too high/too low
11	A5	0	2	0	Icing hazard
12	A6	0	2	1	PSA ^H pressure-operated switch
13	A7	0	2	2	Evaporator coil
14	A8	0	2	1	Condensate warning
15	A9	0	2	1	Condenser fan blocked or defective
16	A10	0	2	1	Evaporator fan blocked or defective
17	A11	0	2	2	Compressor
18	A12	0	2	1	Condenser
19	A13	0	2	1	Ambient temperature sensor
20	A14	0	2	1	Icing temperature sensor
21	A15	0	2	1	Condensate warning temperature sensor
22	A16	0	2	1	Internal temperature sensor
23	A17	0	2	1	Phase monitoring and phase rotation
24	A18	0	2	0	EPROM
25	A19	0	2	0	LAN/Master-Slave

Tab. 4: System messages which may be evaluated via relays

The system messages A1 – A19 may additionally be evaluated via two floating system message relays. In this way, one of the two system message relays may be allocated to each system message.

System alarm relay with normally open contact:

See wiring diagrams at section “4.5.2 Installing the power supply”, page 14:

- Terminal 3: NO (normally open) K2
- Terminal 4: C (connection of the supply voltage to the system message relay)
- Terminal 5: NO (normally open) K1

The NO definition refers to the de-energised state.

As soon as power is applied to the cooling unit, the system message relay picks up, so that the relay contacts change status (contact 3 – 4 closed; contact 4 – 5 closed). This is the normal operating state of the cooling unit. As soon as a system message occurs or the power supply is interrupted, the relay drops out.

Program system messages with the value

- 0: System message is not sent to the system message relays, but merely appears in the display
- 1: System message is evaluated by relay 1
- 2: System message is evaluated by relay 2

6 Operation

EN

6.1.8 Setting the master-slave identifier

When several cooling units are connected together (maximum 10), one of the cooling units must be defined as the “master” and the others as “slaves”. For this purpose, assign a corresponding identifier (address) to each cooling unit which will enable the cooling unit to be identified in the network.

If one of the slave units reaches the set temperature or if the door limit switch function is activated, the affected slave unit will report to the master unit, which then deactivates all the other cooling units.



Notes:

- Only one unit may be configured as master, and its identifier must match the number of connected slave units.
- The slave units must have different identifiers.
- The identifiers must be numbered in ascending order without any gaps.

On the **master cooling unit** (00 = factory setting), set the number of slave units present in the network:

- 01: Master with 1 slave cooling unit
- 02: Master with 2 slave cooling units
- 03: Master with 3 slave cooling units
- 04: Master with 4 slave cooling units
- 05: Master with 5 slave cooling units
- 06: Master with 6 slave cooling units
- 07: Master with 7 slave cooling units
- 08: Master with 8 slave cooling units
- 09: Master with 9 slave cooling units

On the **slave cooling unit** (00 = factory setting), set its own address:

- 11: Slave cooling unit no. 1
- 12: Slave cooling unit no. 2
- 13: Slave cooling unit no. 3
- 14: Slave cooling unit no. 4
- 15: Slave cooling unit no. 5
- 16: Slave cooling unit no. 6
- 17: Slave cooling unit no. 7
- 18: Slave cooling unit no. 8
- 19: Slave cooling unit no. 9

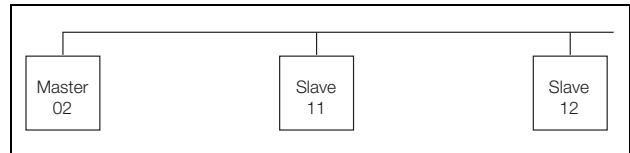

Fig. 27: Master-slave connection (example)

For further connection examples, see “4.5.1 Bus connection (only in conjunction with several units with an e-Comfort controller)”, page 12.

For details of how to set the identifier, see “6.1.5 Editable parameters”, page 19 or “6.1.6 Programming overview”, page 20, parameter “Ad”.

6.1.9 Evaluating system messages

In the e-Comfort controller, system messages are indicated by a number in the display.

Following the appearance of messages A03, A06 and A07 and after rectifying their cause, you will need to reset the e-Comfort controller (see “6.1.10 Resetting the e-Comfort controller”, page 24).

Display screen	System message	Possible cause	Measures to rectify the fault
A01	Enclosure door open	Door open or door limit switch incorrectly positioned	Close door, position door limit switch correctly, check connection if necessary
A02	Internal temperature of enclosure too high	Cooling capacity too low/unit undersized. Error as a consequence of messages A03 to A17.	Check cooling capacity
A03	Filter monitoring	Filter mat soiled	Clean or replace; reset the e-Comfort controller
A04	Ambient temperature too high/too low	Ambient temperature outside of admissible operating range (+10°C to +60°C)	Raise or lower the ambient temperature (e.g. heat or ventilate the room)
A05	Icing hazard	Operational display in case of icing hazard. Evaporator coil fan may be mechanically blocked, defective, or cold air outlet obstructed.	Set the enclosure interior temperature to a higher value. Check the evaporator fan; release or exchange if necessary.
A06	PSA ^H pressure-operated switch	Ambient temperature too high	Lower the ambient temperature; reset the e-Comfort controller
		Condenser soiled	Clean the condenser; reset the e-Comfort controller
		Filter mat soiled	Clean or replace; reset the e-Comfort controller
		Condenser fan defective	Replace; reset the e-Comfort controller
		E-valve defective	Have the sensor repaired by a refrigeration engineer; reset the e-Comfort controller
		PSA ^H pressure-operated switch defective	Have the switch replaced by a refrigeration engineer; reset the e-Comfort controller
A07	Evaporator coil	Lack of coolant; sensor in front of or behind condenser defective	Have the sensor repaired by a refrigeration engineer; reset the e-Comfort controller
A08	Condensate warning	Condensate discharge kinked or blocked	Check condensate discharge; repair any kinks or blockages in the hose as necessary
		Only in units with optional condensate evaporation	Check the evaporation unit, exchange if necessary
A09	Condenser fan	Blocked or defective	Clear the blockage; replace if necessary
A10	Evaporator fan	Blocked or defective	Clear the blockage; replace if necessary
A11	Compressor	Compressor overloaded (internal winding protection)	No action required; unit switches back on automatically
		Defective (check by measuring the winding resistance)	Exchange by refrigeration engineer
A12	Condenser temperature sensor	Open or short-circuit	Replace
A13	Ambient temperature sensor	Open or short-circuit	Replace
A14	Icing temperature sensor	Open or short-circuit	Replace
A15	Condensate warning temperature sensor	Open or short-circuit	Replace
A16	Internal temperature sensor	Open or short-circuit	Replace
A17	Phase monitoring	For three-phase devices only: Incorrect rotary field/phase absent	Exchange two phases
A18	EPROM error	New board obstructed	Software update needed (only following board installation with more recent software): Enter the programming level with Code 22; press button 1 and confirm with "Set" until "Acc" appears. Next, disconnect the unit from the mains and reconnect.
A19	LAN/Master-slave	Master and slave not connected	Check setting and/or cable
A20	Voltage drop	Error display not shown	Event is stored in the log file
E0	Display message	Connection problem between the display and the controller board	Reset: Switch power supply off, then switch on again after approx. 2 sec.
		Cable defective; connection loose	Exchange the boards
OL	Overload	Ambient parameters or heat loss outside of the applicable limits	
b07	Cooling circuit leak	Sensor B3 and B4 mixed up	Correct sensor position
rSt	Reset	Manual device reset required, see "6.1.10 Resetting the e-Comfort controller", page 24.	

Tab. 5: Troubleshooting with the e-Comfort controller

7 Inspection and maintenance

6.1.10 Resetting the e-Comfort controller

After the occurrence of faults A03, A06 and A07, you will need to reset the e-Comfort controller.

- Press buttons 1 (▲) and 3 (▼) simultaneously for 5 seconds.

The system messages will disappear and the temperature display will be shown.

7 Inspection and maintenance



Risk of electric shock!

The unit is live.

Switch off the power supply before opening, and take suitable precautions against it being accidentally switched back on.

7.1 General

The cooling circuit is designed in the form of a maintenance-free, hermetically sealed system. The cooling unit is filled with the required quantity of refrigerant at the factory, checked for leaks, and subjected to a functional test run.

The installed maintenance-free fans are mounted on ball bearings, protected against moisture and dust, and fitted with a temperature monitor. The life expectancy is at least 30,000 operating hours. The cooling unit is thus largely maintenance-free. All that may be required from time to time is to clean the components of the external air circuit using a vacuum cleaner or compressed air if they become visibly dirty. Any stubborn, oily stains may be removed using a non-flammable detergent, such as degreaser. Maintenance interval: 2000 operating hours. Depending on the level of contamination in the ambient air, the maintenance interval may be reduced to suit the air pollution intensity.



Caution!

Risk of fire!

Never use flammable liquids for cleaning.



Note:

On the right of the climate control module, below the socket strip, there is a cover plate to allow easy access to the controller board for maintenance purposes.

Sequence of maintenance measures:

- Check the level of dirt.
- Filter soiling? Replace the filter if necessary.
- Cooling membranes soiled? Clean if necessary.
- Activate test mode; cooling function OK?
- Check noise generation of compressor and fans.



Note:

When carrying out maintenance work, the climate control module must be dismantled off the section door.

7.1.1 Compressed air cleaning

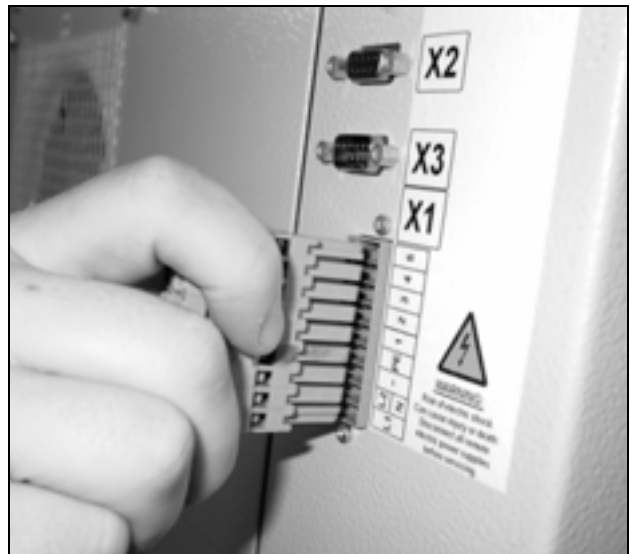

Fig. 28: Disconnect the mains plug



Fig. 29: Disconnect the connector from the display

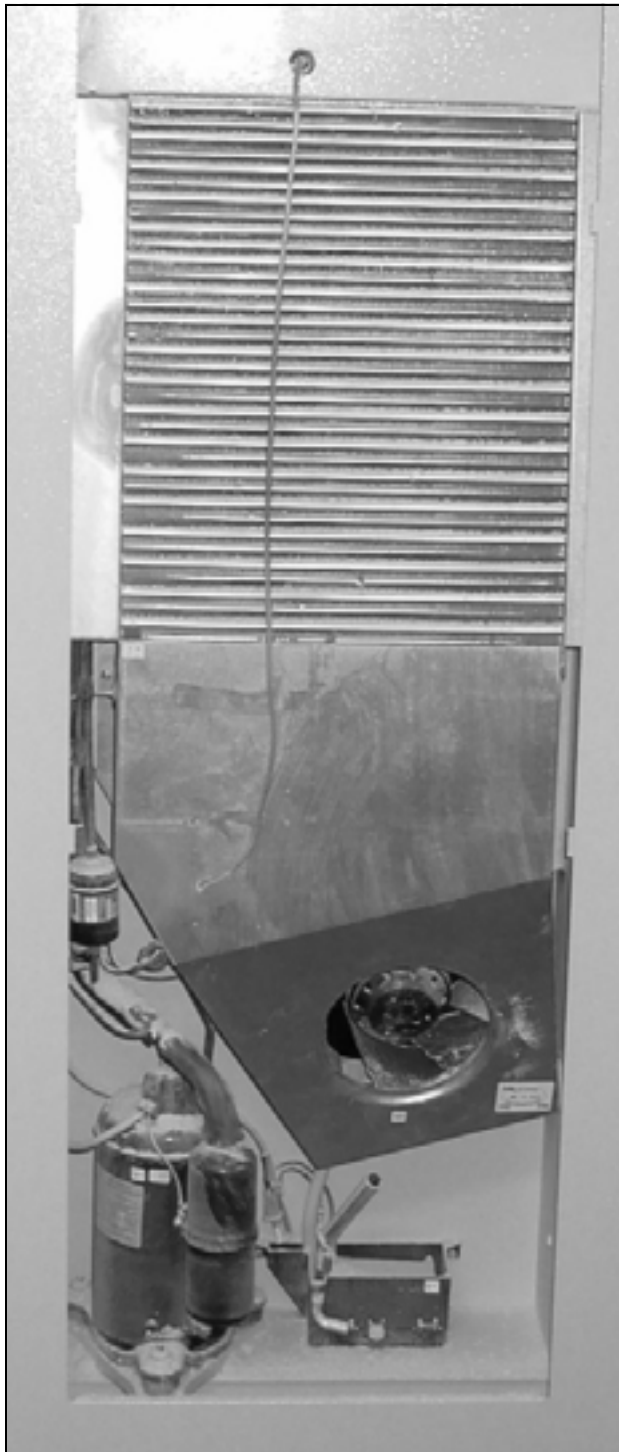

Fig. 30: Climate control module

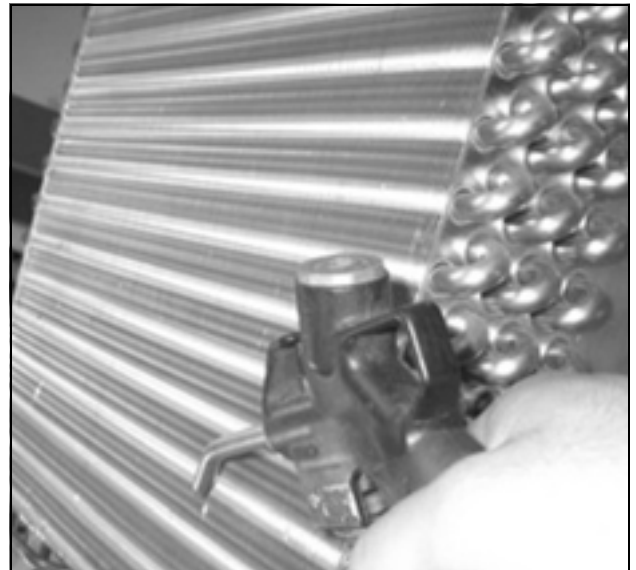

Fig. 31: Clean out the heat exchanger coil and compressor chamber using compressed air

8 Storage and disposal

8 Storage and disposal



Caution! Risk of damage!
The cooling unit must not be subjected to temperatures above +70°C during storage.

The closed cooling circuit contains refrigerant and oil which must be properly disposed of for the sake of the environment. Disposal can be performed at the Rittal plant.
 Please contact us for advice.

9 Technical specifications

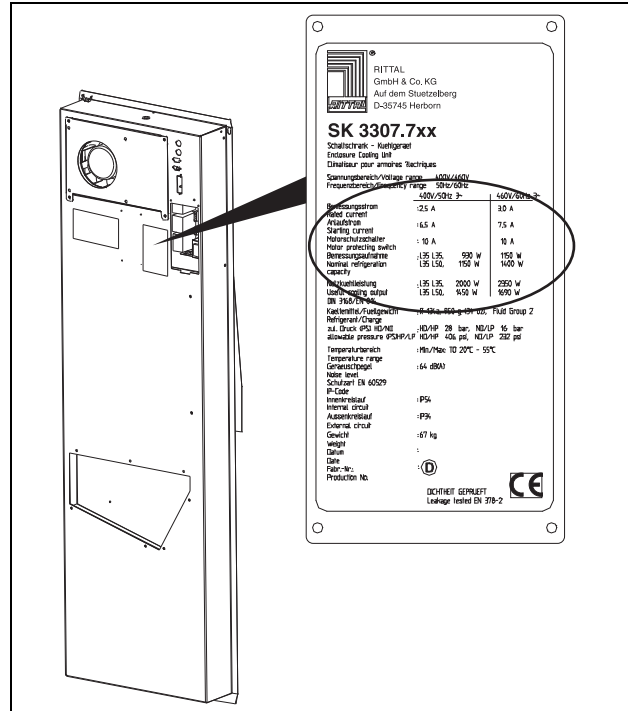

Fig. 32: Rating plate (technical data)

- Observe the mains connection data (voltage and frequency) as per the rating plate.
- Observe the pre-fuse as per the specifications on the rating plate.

	Unit	Model No. SK						
e-Comfort controller	–	3307.700	3307.710	3307.740	3310.700	3310.710	3310.740	
Rated voltage	V Hz	230, 1~, 50/60	115, 1~, 50/60	400, 3~, 50 460, 3~, 60	230, 1~, 50/60	115, 2~, 50/60	400, 3~, 50 460, 3~, 60	
Rated current	A	6.0/6.1	11.2/11.8	2.5/2.7	7.6/9.4	17.3/19.0	3.5/3.7	
Start-up current	A	22.0/24.0	36.0/39.0	8.5/9.2	22.0/24.0	36.0/39.0	13.0/14.0	
Pre-fuse T	A	16.0	11.0 – 16.0	6.3 – 10.0	16.0	18.0 – 25.0	6.3 – 10.0	
Power circuit-breaker	–	–	–	■	–	–	■	
Transformer circuit-breaker	–	–	■	–	–	■	–	
Miniature circuit breaker or fuse gG (T)	–	■	–	–	■	–	–	
Useful cooling output \dot{Q}_k to DIN 3168	L 35 L 35 L 35 L 50	W W	1500/1550 850/900	1500/1550 930/950	2500/2520 1620/1730	2500/2500 1760/1800		
Power consumption P_{el} to DIN 3168	L 35 L 35 L 35 L 50	W W	850/1050 1000/1150	870/1080 1070/1180	790/1000 900/1100	1310/1520 1480/1850	1360/1570 1530/1900	1130/1480 1400/1750
Refrigeration factor $\epsilon = \dot{Q}_k/P_{el}$	–	1.8	1.7	1.9	1.9	1.8	2.2	
Refrigerant – Type – Filling	– g	R134a 700				R134a 1175		
Admissible pressure	bar	28				30		
Temperature setting range	°C	+20 to +55						
Noise level	dB (A)	> 68						
Protection category to EN 60 529 – Internal circuit – External circuit	– –	IP 54 IP 34						
Weight	kg	68	72	68	73	78	72	

Tab. 6: Technical specifications

We reserve the right to make technical modifications.

10 List of spare parts

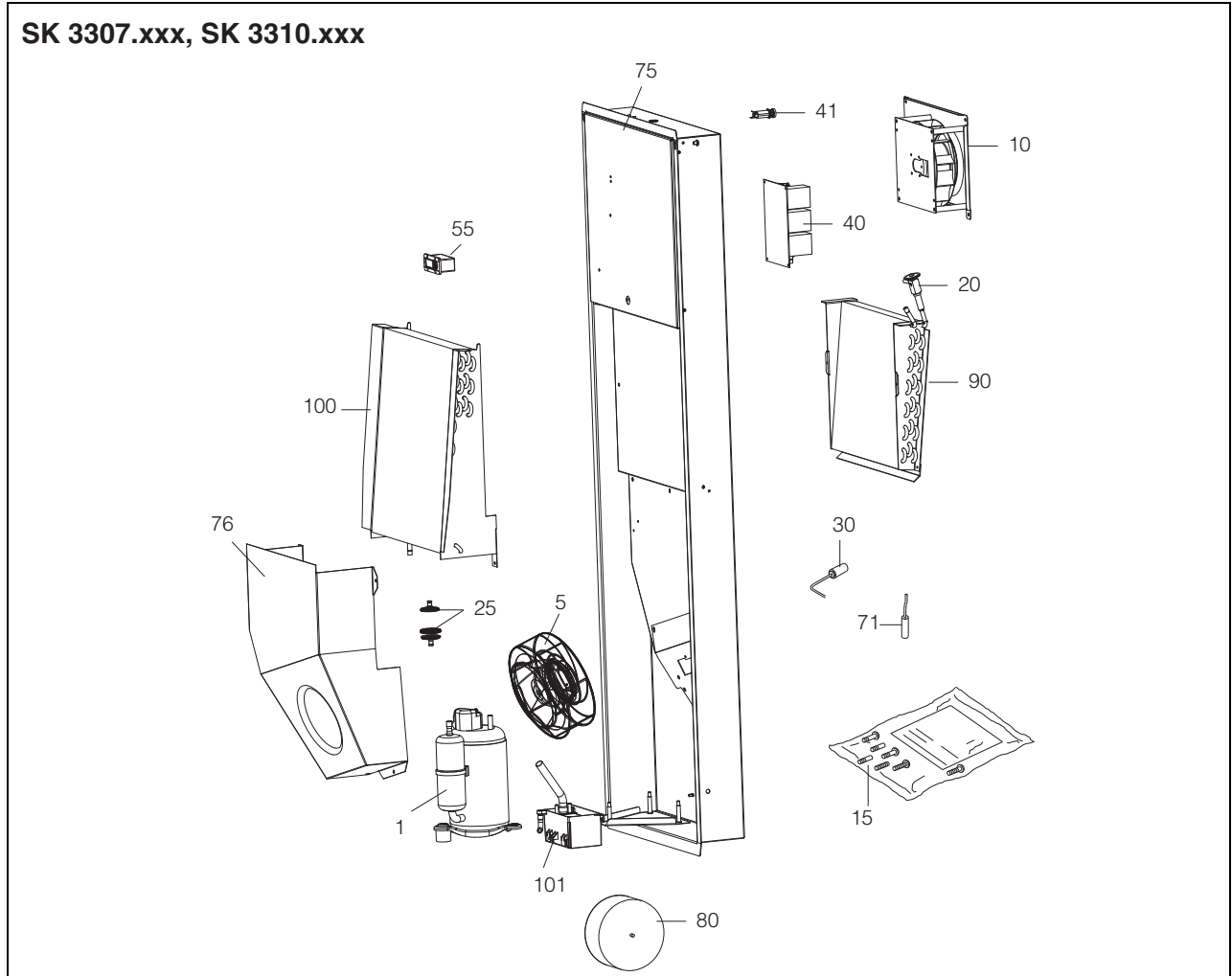

Fig. 33: Spare parts SK 3307.xxx and SK 3310.xxx

Key

- 1 Compressor
- 5 Condenser fan
- 10 Evaporator fan
- 15 Dispatch bag
- 20 Expansion valve
- 25 Filter dryer
- 30 PSA^H pressure-operated switch
- 40 Controller box
- 41 Fuse set, condensate evaporator
- 55 Display (controller)
- 71 Temperature sensor
- 75 Enclosure tray
- 76 Enclosure tray, fan
- 80 Transformer
- 90 Evaporator coil
- 100 Condenser
- 101 Condensate evaporator



Note:

As well as the spare part number, when ordering spare parts the following information must be provided:

- Unit model
- Fabrication number
- Date of manufacture

This information may be found on the rating plate.

Rittal – The System.

Faster – better – worldwide.

- Enclosures
- Power Distribution
- Climate Control
- IT Infrastructure
- Software & Services

RITTAL GmbH & Co. KG
Postfach 1662 · D-35726 Herborn
Phone +49(0)2772 505-0 · Fax +49(0)2772 505-2319
E-mail: info@rittal.de · www.rittal.com

ENCLOSURES

POWER DISTRIBUTION

CLIMATE CONTROL

IT INFRASTRUCTURE

SOFTWARE & SERVICES



FRIEDHELM LOH GROUP